

LiftMaster®

OWNER'S MANUAL MODEL GH INDUSTRIAL DUTY DOOR OPERATOR

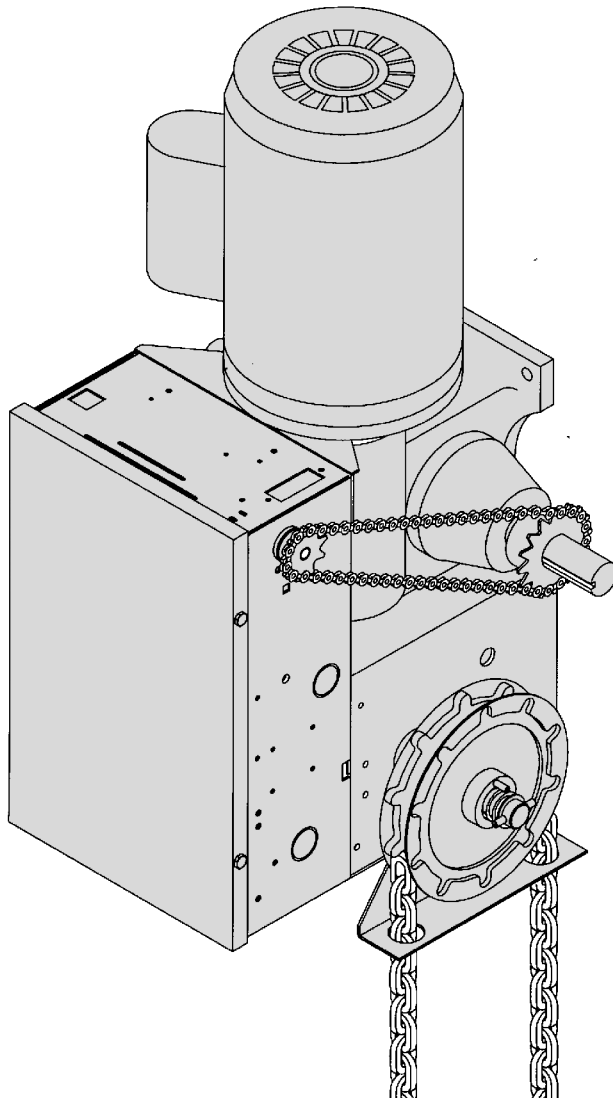

NOT FOR RESIDENTIAL USE

Chamberlain Australia Pty Ltd
PO BOX 1446
Lane Cove NSW 1595
AUSTRALIA
middleeast@chamberlainanz.com



SPECIFICATIONS

MOTOR

TYPE:Continuous duty
HORSEPOWER:.....1/2, 3/4, 1 & 1-1/2 Hp
 Single or Three phase
 2 HP Three phase
SPEED:.....1725 RPM
VOLTAGE:115, 220, 230 Single phase
 230, 460, 575 Three phase
CURRENT:See motor nameplate

ELECTRICAL

TRANSFORMER:.....24VAC
CONTROL STATION:NEMA 1 three button station.
 OPEN/CLOSE/STOP
WIRING TYPE:.....C2 (Standard)
 Momentary contact to OPEN/CLOSE/STOP plus wiring
 for sensing device to reverse and auxiliary devices to
 open and close with open override.
 (Other types available. See chart, Pg. 8)
LIMIT ADJUST:Linear driven, fully
 adjustable screw type cams. Adjustable to 30 feet.

MECHANICAL

DRIVE REDUCTION:.....**40:1 Reduction**
 Heavy duty bronze worm
 gear reducer
OUTPUT SHAFT SPEED:.....43 R.P.M.
DOOR SPEED:4 - 10" per sec.
 depending on door
BRAKE:Solenoid actuated disc
 brake
HOIST WHEEL:Standard mounting on
 left or right side

SAFETY

DISCONNECT:Floor level chain hoist with elect-
 rical interlock for emergency manual door operation
CLUTCH: (optional)....Adjustable torque limiter type
REVERSING EDGE:.....(Optional) Electric or pneumatic
 sensing device attached to the bottom edge of door.
**A REVERSING EDGE IS STRONGLY
 RECOMMENDED FOR ALL COMMERCIAL
 OPERATOR INSTALLATIONS. REQUIRED WHEN
 THE 3 BUTTON CONTROL STATION IS OUT OF
 SIGHT OF DOOR OR ANY OTHER CONTROL
 (AUTOMATIC OR MANUAL) IS USED.**

WEIGHTS AND DIMENSIONS

HANGING WEIGHT:80-110 LBS.

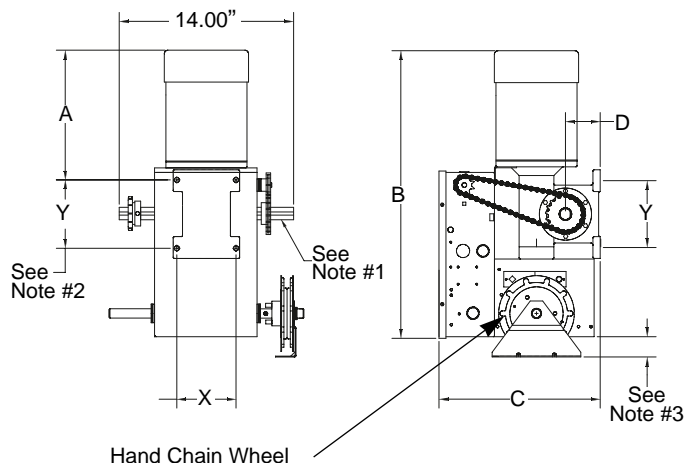

HP	PHASE	DIMENSIONS			
		A	B	C	D
1/2	1	11-1/2	25-3/4	12-63/64	3
3/4	1	12-1/2	26-3/4	12-63/64	3
1	1	12-3/4	27	12-63/64	3
1-1/2	1	12-3/4	27	13-63/64	3-1/2
1/2	3	11	25-1/4	12-63/64	3
3/4	3	11	25-1/4	12-63/64	3
1	3	12	26-1/4	12-63/64	3
1-1/2	3	12-1/2	26-3/4	13-63/64	3-1/2
2	3	12-3/4	27	13-63/64	3-1/2
3	3	13-1/4	28-5/8	15-15/64	3

NOTES:

- 1) Output Shaft with 1" x 1/4" Key for 1/2 thru 2Hp operators, 1-1/4" x 1/4" Key for 3Hp operators.
- 2) MT'G CENTERS: X = 4-3/4"; Y = 5-1/2" for 1/2 thru 2Hp operators
 X = 7-17/32"; Y = 9-1/16" for 3Hp operators
- 3) Hand Chain Wheel extends 1-5/8" beyond operator in vertical mounting position as shown.

IMPORTANT SAFETY NOTES



CAUTION

TO AVOID DAMAGE TO DOOR AND OPERATOR, MAKE ALL DOOR LOCKS INOPERATIVE. SECURE LOCK(S) IN "OPEN" POSITION.

IF THE DOOR LOCK NEEDS TO REMAIN FUNCTIONAL, INSTALL AN INTERLOCK SWITCH.

DO NOT CONNECT ELECTRIC POWER UNTIL INSTRUCTED TO DO SO.



WARNING

KEEP DOOR BALANCED. STICKING OR BINDING DOORS MUST BE REPAIRED. DOORS, DOOR SPRINGS, CABLES, PULLEYS, BRACKETS AND THEIR HARDWARE MAY BE UNDER EXTREME TENSION AND CAN CAUSE SERIOUS PERSONAL INJURY. CALL A PROFESSIONAL DOOR SERVICEMAN TO MOVE OR ADJUST DOOR SPRINGS OR HARDWARE.

SITE PREPARATIONS

It is imperative that the wall or mounting surface provide adequate support for the operator.

This surface must:

- Be rigid to prevent play between operator and door shaft.
- Provide a level base.
- Permit the operator to be fastened securely and with the drive shaft parallel to the door shaft.

The safety and wear of the operator will be adversely affected if any of the above requirements are not met.

For metal buildings, fasten 2" x 2" x 3/16" (or larger) angle iron frames to the building purlins. Retain 5-1/2" between frames. See Figure 1.

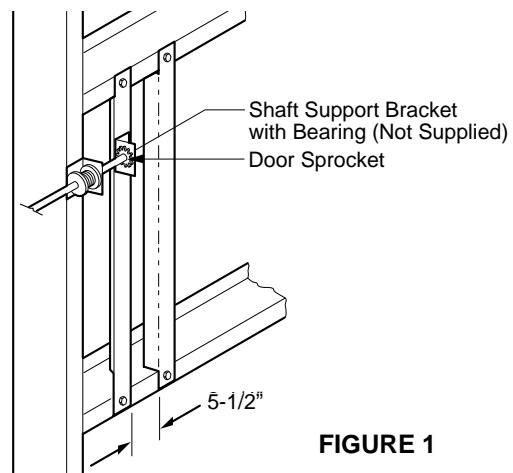

FIGURE 1

OPERATOR PREPARATION

The GH operator may be mounted on either the right (standard) or left side of door, and in either a vertical (standard) or horizontal mounting position. Refer to the steps below if you require the hand chain and/or disconnect chain to be on the opposite side of the operator; Or if the operator is being mounted in a horizontal position.

Hand Chain Right/Left Conversion

Remove the two snap rings (1 pc. outer, 1 pc inner) on hand chain shaft assembly. Position roll-pin to fit through cutout in frame and slide complete shaft assembly through housing and bevel gear. Insert shaft assembly on opposite side of housing, and replace bevel gear, bearing, hardware, and snap rings on the opposite side of shaft in the same manner.

Disconnect Lever Right/Left Conversion

Remove cotter pins on the ends of the disconnect shaft (square shaft), move the disconnect lever arm to the opposite side, and replace the cotter pins. Be sure to keep two(2) 12ga. washers on the side without the lever arm.

Horizontal Mounting Conversion

Remove cotter pins on the ends of the disconnect shaft (square shaft), and remove lever. Replace lever using square hole on opposite end of lever. Reposition sash chain to opposite end of lever also. Replace cotterpins.

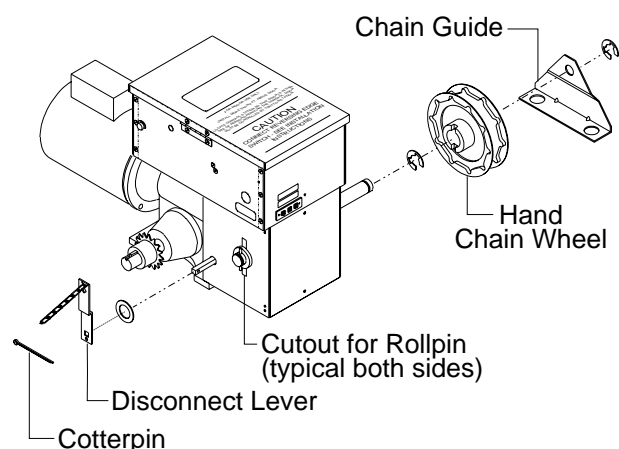

FIGURE 2

OPERATOR MOUNTING

Before your operator is installed, be sure the door has been properly aligned and is working smoothly. The operator may be wall mounted or mounted on a bracket or shelf. If necessary, refer to the operator preparations on page 3. Refer to the illustration and instructions below that suits your application.

1a. Wall Mounting

The operator should generally be installed below the door shaft, and as close to the door as possible. The optimum distance between the door shaft and operator drive shaft is between 12" - 15". Refer to Figure 3.

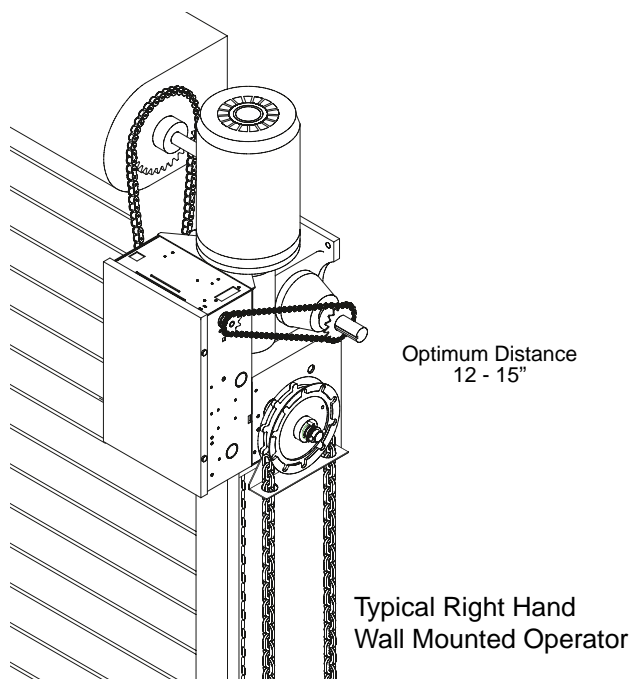
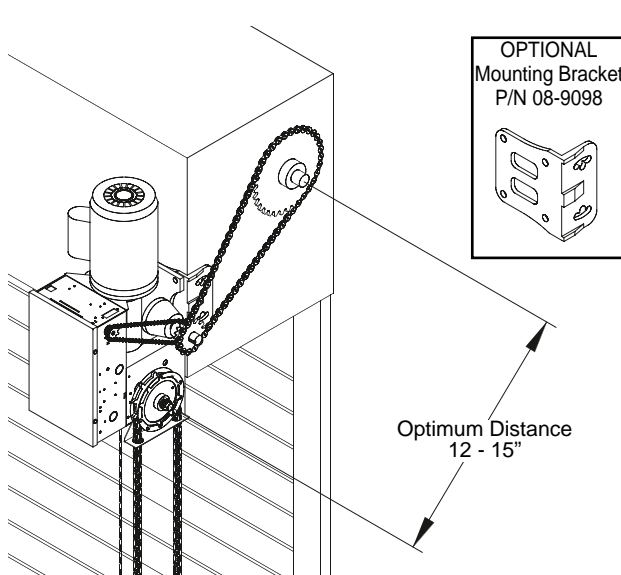

FIGURE 3

1b. Bracket or Shelf Mounting

The operator may be mounted either above or below the door shaft. The optimum distance between the door shaft and operator drive shaft is between 12" - 15". Refer to Figure 4.



IMPORTANT: The shelf or bracket must provide adequate support, prevent play between operator and door shaft, and permit operator to be fastened securely and with the drive shaft parallel to the door shaft.

FIGURE 4

- 1c. Place door sprocket on the door shaft. Do not insert the key at this time.
2. Place drive sprocket on the appropriate side of the operator. Do not insert the key at this time.
3. Wrap drive chain around door sprocket and join roller chain ends together with master link.
4. Raise operator to approximate mounting position and position chain over operator sprocket.
5. Raise or lower operator until the chain is taut (not tight). Make sure the operator output shaft is parallel to door shaft and sprockets are aligned. When in position, secure the operator to wall or mounting bracket.
6. Align sprockets and secure, (see Figure 5).

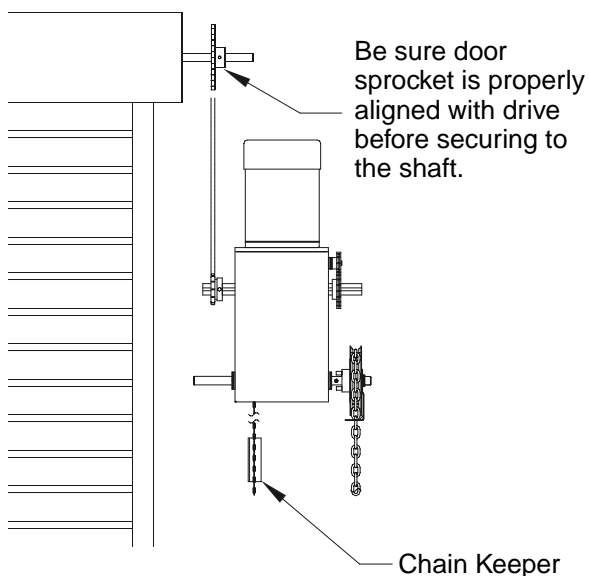

FIGURE 5

7. Install Hand Chain

Place hand chain around hand chain wheel. Be sure to pass it through both openings in the chain guide. Remove enough links so chain hangs approximately two feet above the floor

8. Mount Chain Keeper / Keyhole Bracket

Using suitable hardware mount the chain keeper approximately 4 feet above the floor, near the free hanging chain. Remove disconnect sash chain from bag and place the end through the keyhole in the the chain keeper. Remove excess links if necessary.

EMERGENCY MANUAL OPERATION

This operator has provisions for manually operating the door in case of emergency or power failure. Refer to the appropriate instructions below for your model operator.

Model GH

These operators are equipped with a manual hoist. An electrical interlock will disable the electrical controls when the hoist is used.

To operate the hoist:

1. Pull the disconnect chain (small chain) to engage the hoist mechanism. The disconnect chain may be locked in position by slipping the end through the keyhole of the chain keeper mounted on the wall.
2. Operate the door in the desired direction by pulling on one side or the other of the continuous loop hoist chain (large chain).
3. The disconnect chain must be released from the chain keeper before the door will operate again electrically.

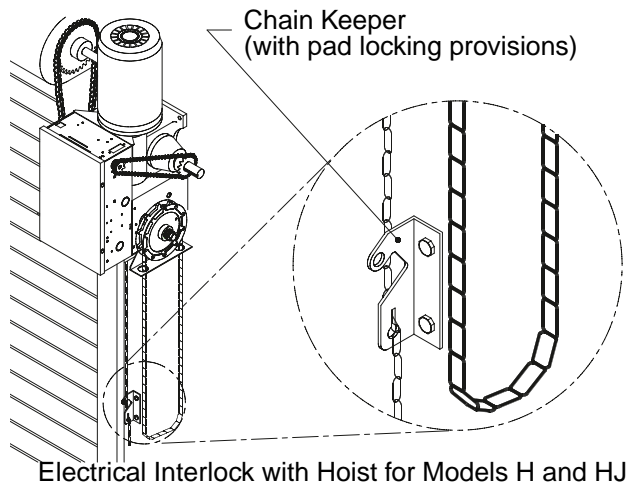

BRAKE ADJUSTMENT

The brake is adjusted at the factory and should not need additional adjustment for the the life of the friction pad. Replace friction pads when necessary. Refer to the illustration for identification of components for the solenoid type brake system.

Solenoid Brake System

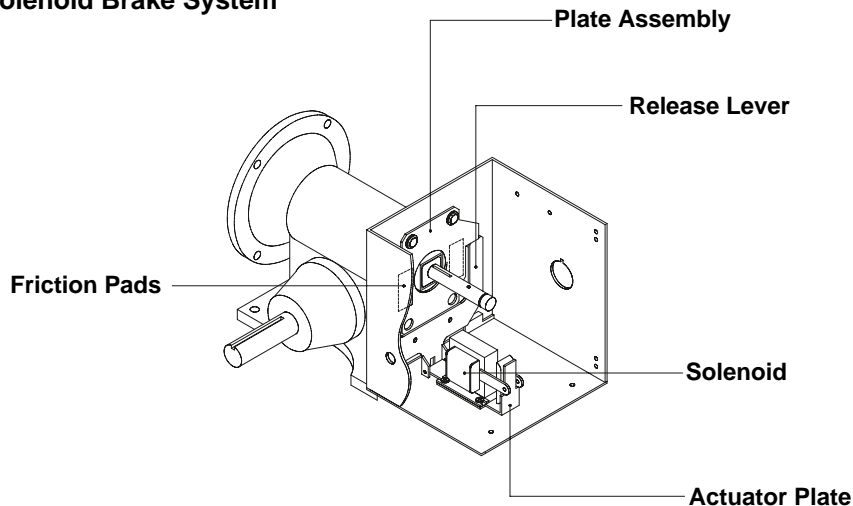

ENTRAPMENT PROTECTION ACCESSORIES (OPTIONAL)

SENSING EDGES & PHOTO EYES

Sensing devices supplied for door industry type operators with an isolated normally open (N.O.) output are compatible with your operator. This includes pneumatic and electric edges, and through beam and retro reflective photo eyes. If your door does not have a bottom sensing edge or safety photo eyes and you wish to add a safety device to your application, please contact your local LiftMaster Authorized Dealer.

If not pre-installed by the door manufacturer, mount the sensing edge on the door according to the instructions provided with the edge. The sensing edge may be electrically connected by either coiled cord or take-up reel. Refer to the steps below.

Important Notes:

- Proceed with Limit Switch Adjustments before making any sensing edge wiring connections to operator as described below.
- Electrician must hardwire the junction box to the operator electrical box in accordance with local codes.

NOTICE

IT IS STRONGLY RECOMMENDED THAT A SAFETY PHOTO EYE OR SENSING EDGE BE USED IN CONJUNCTION WITH THE OPERATOR.

WIRING:

For wiring of your sensing device to the operator, refer to the wiring diagram supplied with your operator. See field connection terminals identified as Sensing Device or Safety Edge.

TAKE-UP REEL: Take-up reel should be installed 12" above the top of the door.

COIL CORD: Connect operator end of coil cord to junction box (not supplied) fastened to the wall approximately halfway up the door opening.

LIMIT SWITCH ADJUSTMENT

MAKE SURE THE LIMIT NUTS ARE POSITIONED BETWEEN THE LIMIT SWITCH ACTUATORS BEFORE PROCEEDING WITH ADJUSTMENTS.

- To adjust limit nuts depress retaining plate to allow nut to spin freely. After adjustment, release plate and ensure it seats fully in slots of both nuts.
- To **increase** door travel, spin nut **away** from actuator. To **decrease** door travel, spin limit nut **toward** actuator.
- Adjust open limit nut so that door will stop in open position with the bottom of the door even with top of door opening.
- Repeat Steps 1 and 2 for close cycle. Adjust close limit nut so that actuator is engaged as door fully seats at the floor.



WARNING

TO AVOID SERIOUS PERSONAL INJURY OR DEATH FROM ELECTROCUTION, DISCONNECT ELECTRIC POWER BEFORE MANUALLY MOVING LIMIT NUTS.

If other problems persist, call our toll-free number for assistance - 1-800-528-2806.

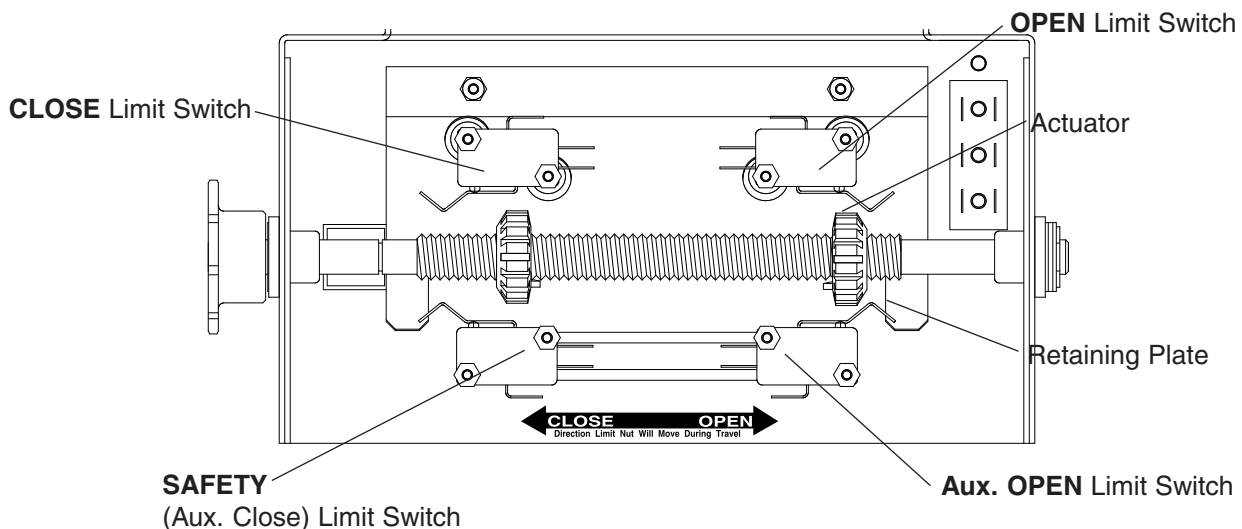

POWER WIRING CONNECTIONS

Remove the cover from the electrical enclosure. Inside this enclosure you will find the wiring diagram(s) for your unit. Refer to the diagram (glued on the inside of the cover) for all connections described below. If this diagram is missing, call the number on the back of this manual. **DO NOT INSTALL ANY WIRING OR ATTEMPT TO RUN THIS OPERATOR WITHOUT CONSULTING THE WIRING DIAGRAM.**

POWER WIRING

1. Be sure that the power supply is of the correct voltage, phase, frequency, and amperage to supply the operator. Refer to the operator nameplate on the cover.
2. Using the 1-1/16" dia conduit access knockout as shown below, bring supply lines to the operator and connect wires to the terminals indicated on the WIRING CONNECTIONS DIAGRAM.

DO NOT TURN POWER ON UNTIL YOU HAVE FINISHED MAKING ALL POWER AND CONTROL WIRING CONNECTIONS AND HAVE COMPLETED THE LIMIT SWITCH ADJUSTMENT PROCEDURE.

CAUTION: THIS UNIT MUST BE PROPERLY GROUNDED. A GROUND SCREW IS SUPPLIED IN THE ELECTRICAL BOX FOR CONNECTION OF THE POWER SUPPLY GROUND WIRE. FAILURE TO PROPERLY GROUND THIS UNIT COULD RESULT IN ELECTRIC SHOCK AND SERIOUS INJURY.

ON THREE PHASE MACHINES ONLY!

Incorrect phasing of the power supply will cause the motor to rotate in the wrong direction (open when CLOSE button is pressed and vice-versa). To correct this, interchange any two of the incoming three phase power lines.

CONDUIT ACCESS

1-1/16" Dia Knockout for power wiring conduit access (1 nearside)

WARNING
Do Not Run Power & Control Wiring in the Same Conduit

7/8" Dia Knockouts for power wiring conduit access (2 on end panel)

**WARNING**

DISCONNECT POWER AT THE FUSE BOX BEFORE PROCEEDING.

OPERATOR MUST BE PROPERLY GROUNDED AND CONNECTED IN ACCORDANCE WITH LOCAL ELECTRICAL CODES. NOTE: THE OPERATOR SHOULD BE ON A SEPARATE FUSED LINE OF ADEQUATE CAPACITY.

ALL ELECTRICAL CONNECTIONS MUST BE MADE BY A QUALIFIED INDIVIDUAL.

**WARNING**

TO AVOID DAMAGE TO DOOR AND OPERATOR, MAKE ALL DOOR LOCKS INOPERATIVE. SECURE LOCK(S) IN "OPEN" POSITION.

IF THE DOOR LOCK NEEDS TO REMAIN FUNCTIONAL, INSTALL AN INTERLOCK SWITCH.

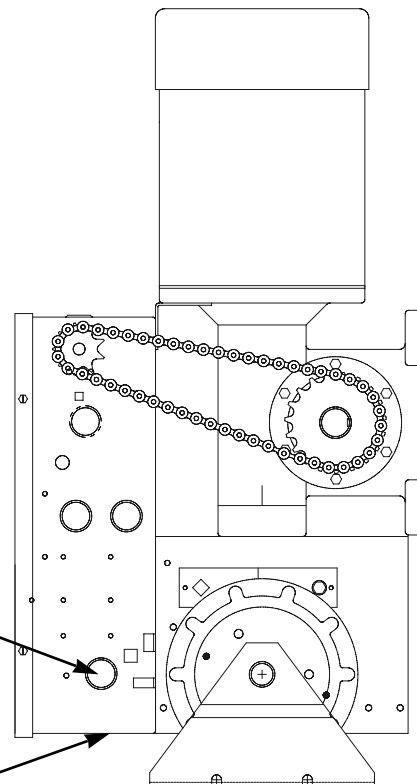

CONTROL WIRING

DETERMINE WIRING TYPE

Refer to the wiring diagram located on the inside cover of the electrical box to determine the type of control wiring.

Standard C2 or B2 Wiring

Standard operators are shipped from the factory with a jumper set for C2 wiring, which requires constant pressure on the button to close the door. If momentary contact on close direction is desired (B2 wiring) you must include an entrapment protection device. See close control jumper setting below.

- **Constant pressure on close (C2 wiring)**
Red jumper wire was placed on terminal #2 in the electrical enclosure. The operator will require constant pressure on close control in order to keep the door moving in the close direction.
- **Momentary contact on close (B2 wiring)**
Move red jumper wire from terminal #2 to terminal #3. The operator will require only momentary contact to close the door.

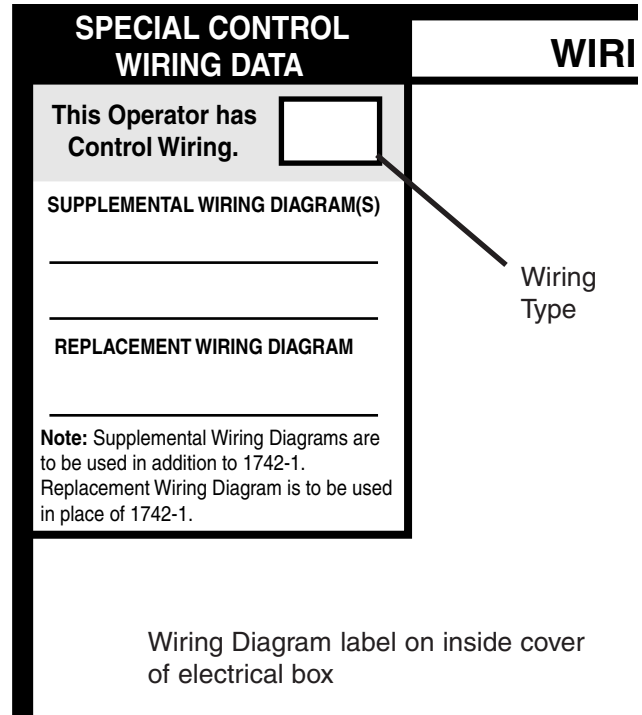

SPECIAL CONTROL WIRING

If your operator was shipped from the factory with non-standard control wiring or with optional accessories that require additional instructions, refer to the wiring diagram(s) indicated in the special control wiring data box. When a replacement wiring diagram is present, wiring diagrams in this manual will not apply. Refer only to the replacement wiring diagram for all connections.

IMPORTANT NOTE: If your wiring diagram is missing, or you are unsure of the wiring type for your operator, contact the customer service department @ 1-800-528-2806.

LOCATING THE CONTROL STATION

All operators are supplied with some type of control station. Generally a three-button station (OPEN/CLOSE/STOP) is provided. A two-position key switch or control station (OPEN/CLOSE) may be added or substituted when requested at the time of order. Mount the control station near the door.



WARNING

INSTALL THE CONTROL STATION WHERE THE DOOR IS VISIBLE, BUT AWAY FROM THE DOOR AND ITS HARDWARE. IF CONTROL STATION CANNOT BE INSTALLED WHERE DOOR IS VISIBLE, OR IF ANY DEVICE OTHER THAN THE CONTROL STATION IS USED TO ACTIVATE THE DOOR, A REVERSING EDGE MUST BE INSTALLED ON THE BOTTOM OF THE DOOR. FAILURE TO INSTALL A REVERSING EDGE UNDER THESE CIRCUMSTANCES MAY RESULT IN SERIOUS INJURY OR DEATH TO PERSONS TRAPPED BENEATH THE DOOR.

MOUNT WARNING NOTICE

IMPORTANT: Mount WARNING NOTICE beside or below the push button station.

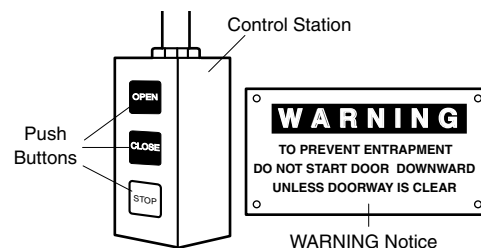

CONTROL WIRING (con't)

Radio Controls

On all models with type B2 control wiring, a terminal bracket marked R1 R2 R3 is located on the outside of the electrical enclosure. All standard radio control receivers (single channel residential type) may be mounted to this bracket. The operator will then open a fully closed door, close a fully open door, and reverse a closing door from the radio transmitter. However, for complete door control from a transmitter, a commercial three-channel radio set (with connections for OPEN/CLOSE/STOP) is recommended.



WARNING

DO NOT USE RADIO CONTROLS WITH YOUR OPERATOR UNLESS YOU HAVE INSTALLED SOME TYPE OF ENTRAPMENT PROTECTION DEVICE. THE USE OF RADIO CONTROLS PRESENTS POTENTIAL HAZARDS DUE TO THE USER'S ABILITY TO OPEN OR CLOSE THE DOOR WHEN OUT OF SIGHT OF THE DOOR. IN ADDITION, IF A SINGLE CHANNEL CONTROL IS USED, THE USER WILL NOT BE ABLE TO STOP THE DOOR FROM THE TRANSMITTER.

Additional Access Control Equipment

Locate any additional access control equipment as desired (but so that the door will be in clear sight of the person operating the equipment), and connect to the terminal block in the electrical enclosure as shown on the FIELD WIRING CONNECTIONS diagram. Any control with a normally (N.O.) isolated output contact may be connected in parallel with the OPEN button. More than one device may be connected in this manner. Use 16 gauge wire or larger for all controls. **DO NOT USE THE CONTROL CIRCUIT TRANSFORMER (24VAC) IN THE OPERATOR TO POWER ANY ACCESS CONTROL EQUIPMENT OTHER THAN A STANDARD RESIDENTIAL TYPE RADIO RECEIVER.**

External Interlock Switch

The operator has a terminal connection for an external interlock switch. This switch must be a normally closed (N.C.) two-wire device with a contact rating of at least 3 amps @ 24VAC. When such a switch is connected as shown on the FIELD WIRING CONNECTIONS diagram, the control circuit will be disabled when the switch is actuated, thereby preventing electrical operation of the door from the control devices.

CLUTCH ADJUSTMENT (OPTIONAL MODIFICATION)

1. Loosen set screws on clutch nut.
2. Back off clutch nut until there is very little tension on the clutch spring.
3. Tighten clutch nut gradually until there is just enough tension to permit the operator to move the door smoothly but to allow the clutch to slip if the door is obstructed. When the clutch is properly adjusted, it should generally be possible to stop the door by hand during travel.

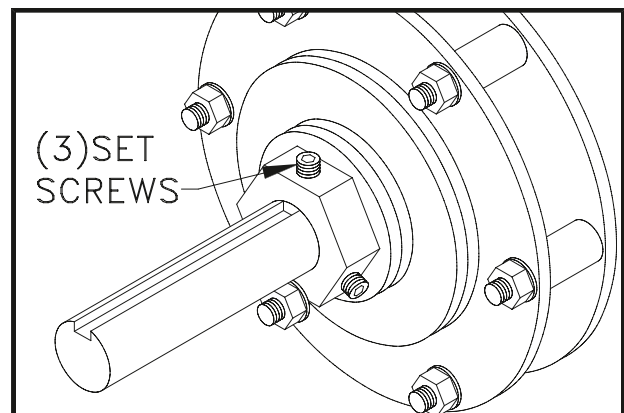

WARNING

TO AVOID SERIOUS PERSONAL INJURY OR DEATH FROM ELECTROCUTION, DISCONNECT ELECTRIC POWER TO OPERATOR BEFORE ADJUSTING SLIP CLUTCH.

CAUTION: The torque limiter clutch is **NOT** an automatic reversing device. An electric or pneumatic reversing edge can be added to bottom edge of door if desired.

CONNECT REVERSING EDGE DEVICE (OPTIONAL)



WARNING

IF CONTROL STATION CANNOT BE INSTALLED WHERE DOOR IS VISIBLE, OR IF ANY DEVICE OTHER THAN THE CONTROL STATION IS USED TO ACTIVATE THE DOOR, A REVERSING EDGE **MUST BE INSTALLED ON THE BOTTOM OF THE DOOR**. FAILURE TO INSTALL A REVERSING EDGE UNDER THESE CIRCUMSTANCES MAY RESULT IN SERIOUS PERSONAL INJURY OR DEATH TO PERSONS TRAPPED BENEATH THE DOOR.

The operator has been pre-wired to accept connection of a reversing edge device. Connect the normally open contacts to terminals T4 and T8 on the low voltage terminal block. A cut-off switch will deactivate the safety device during the last few inches of the door's downward travel.

NOTICE:

This equipment has been tested and found to comply with the limits for a Class A digital device, pursuant to Part 15 of the FCC Rules. These limits are designed to provide reasonable protection against harmful interference when the equipment is operated in a commercial environment. This equipment generates, uses, and can radiate radio frequency energy and, if not installed and used in accordance with the instruction manual, may cause harmful interference to radio communications. Operation of this equipment in a residential area is likely to cause harmful interference, in which case the user will be required to correct the interference at his own expense.

TEST THE SYSTEM

Turn on power. Test all controls and safety devices to make sure they are working properly. It will be necessary to refer back to page 6 for fine adjustment of the limit switches.

IMPORTANT NOTES:

- Do not leave operator power on unless all safety and entrapment protection devices have been tested and are working properly.
- Be sure you have read and understand all Safety Instructions included in this manual.
- Be sure the owner or person(s) responsible for operation of the door have read and understand the Safety Instructions, know how to electrically operate the door in a safe manner, and know how to use the manual disconnect operation of the door operating system.



WARNING

DO NOT PLACE HANDS OR TOOLS IN OR NEAR THE OPERATOR WHEN THE POWER IS ON OR WHEN TESTING CONTROL OR SAFETY DEVICES. ALWAYS DISCONNECT POWER BEFORE SERVICING OR ADJUSTING THE OPERATOR.

MAINTENANCE SCHEDULE

Check at the intervals listed in the following chart.

ITEM	PROCEDURE	EVERY 3 MONTHS	EVERY 6 MONTHS	EVERY 12 MONTHS
Drive Chain	Check for excessive slack. Check & adjust as required. Lubricate.*	●		●
Sprockets	Check set screw tightness	●		●
Fasteners	Check & tighten as required		●	●
Manual Disconnect	Check & Operate		●	●
Bearings & Shafts	Check for wear & lubricate	●		●

- ◆ Use SAE 30 Oil (Never use grease or silicone spray).
- Repeat ALL procedures.
- Do not lubricate motor. Motor bearings are rated for continuous operation.
- Inspect and service whenever a malfunction is observed or suspected.
- CAUTION: BEFORE SERVICING, ALWAYS DISCONNECT OPERATOR FROM POWER SUPPLY.

HOW TO ORDER REPAIR PARTS

OUR LARGE SERVICE ORGANIZATION
SPANS AMERICA
INSTALLATION AND SERVICE INFORMATION
ARE AVAILABLE 6 DAYS A WEEK
CALL OUR TOLL FREE NUMBER - 1-800-528-2806
HOURS 7:00 TO 3:30 p.m. (Mountain Std. Time)
MONDAY Through SATURDAY

**WHEN ORDERING REPAIR PARTS
PLEASE SUPPLY THE FOLLOWING INFORMATION:**

PART NUMBER DESCRIPTION MODEL NUMBER

ADDRESS ORDER TO:

THE CHAMBERLAIN GROUP, INC.
Electronic Parts & Service Dept.
2301 N. Forbes Blvd., Suite 104
Tucson, AZ 85745

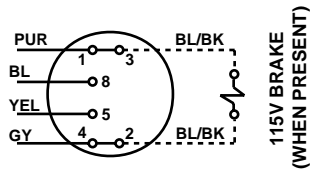

115 VOLT - 1 PHASE MOTOR CONNECTION

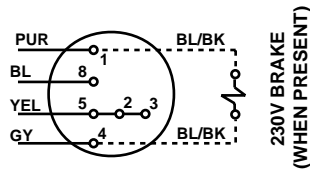

230 VOLT - 1 PHASE MOTOR CONNECTION

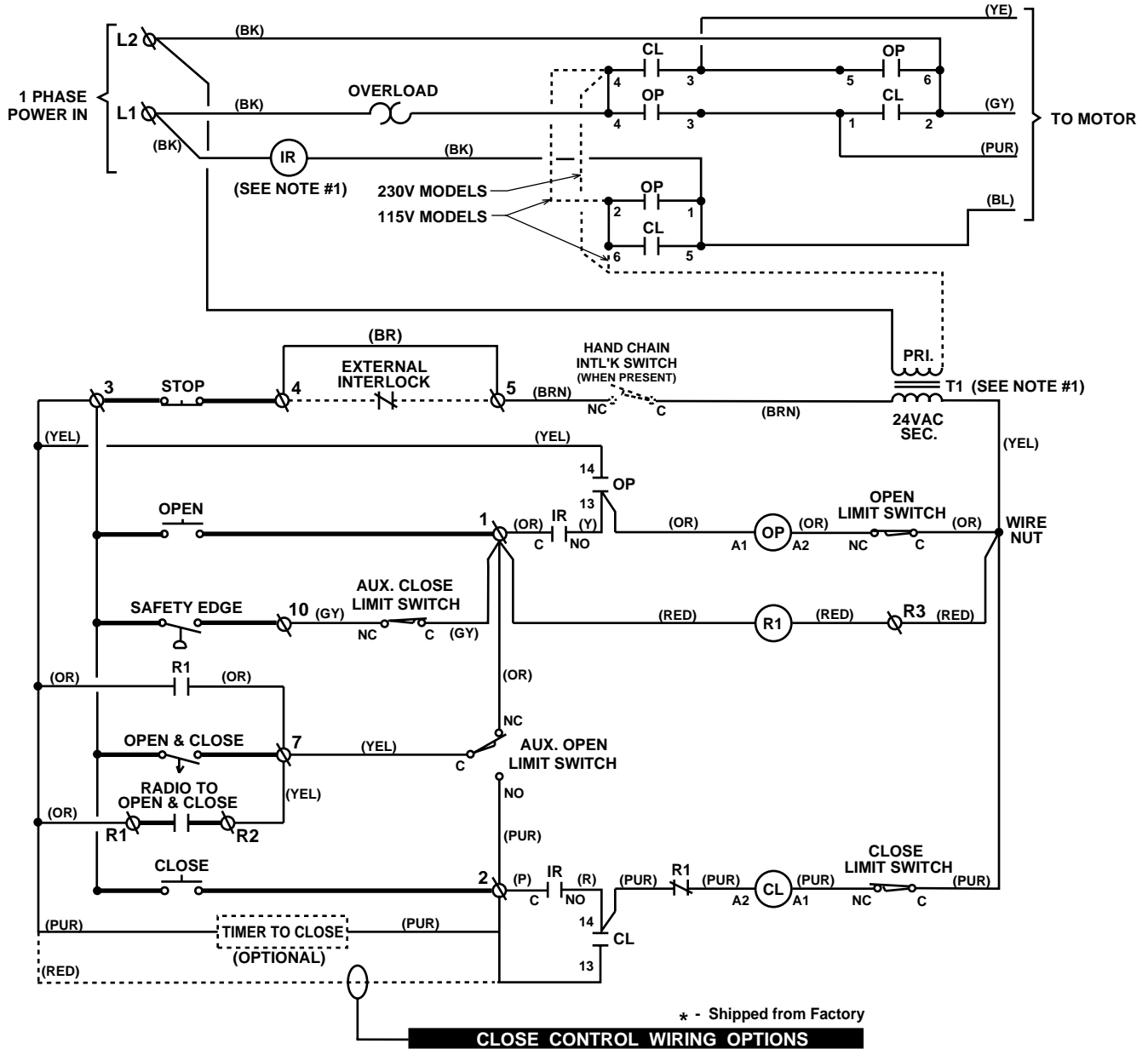

* - Shipped from Factory

CLOSE CONTROL WIRING OPTIONS

*C2 WIRING - Constant Pressure to Close
 RED WIRE ON TERMINAL #2 (Shipped from Factory)

B2 WIRING - Momentary Contact to Close
 MOVE RED WIRE FROM TERMINAL #2 TO TERMINAL #3

NOTE:
 1. Voltage same as line voltage.

SINGLE PHASE WIRING DIAGRAM

1742-1

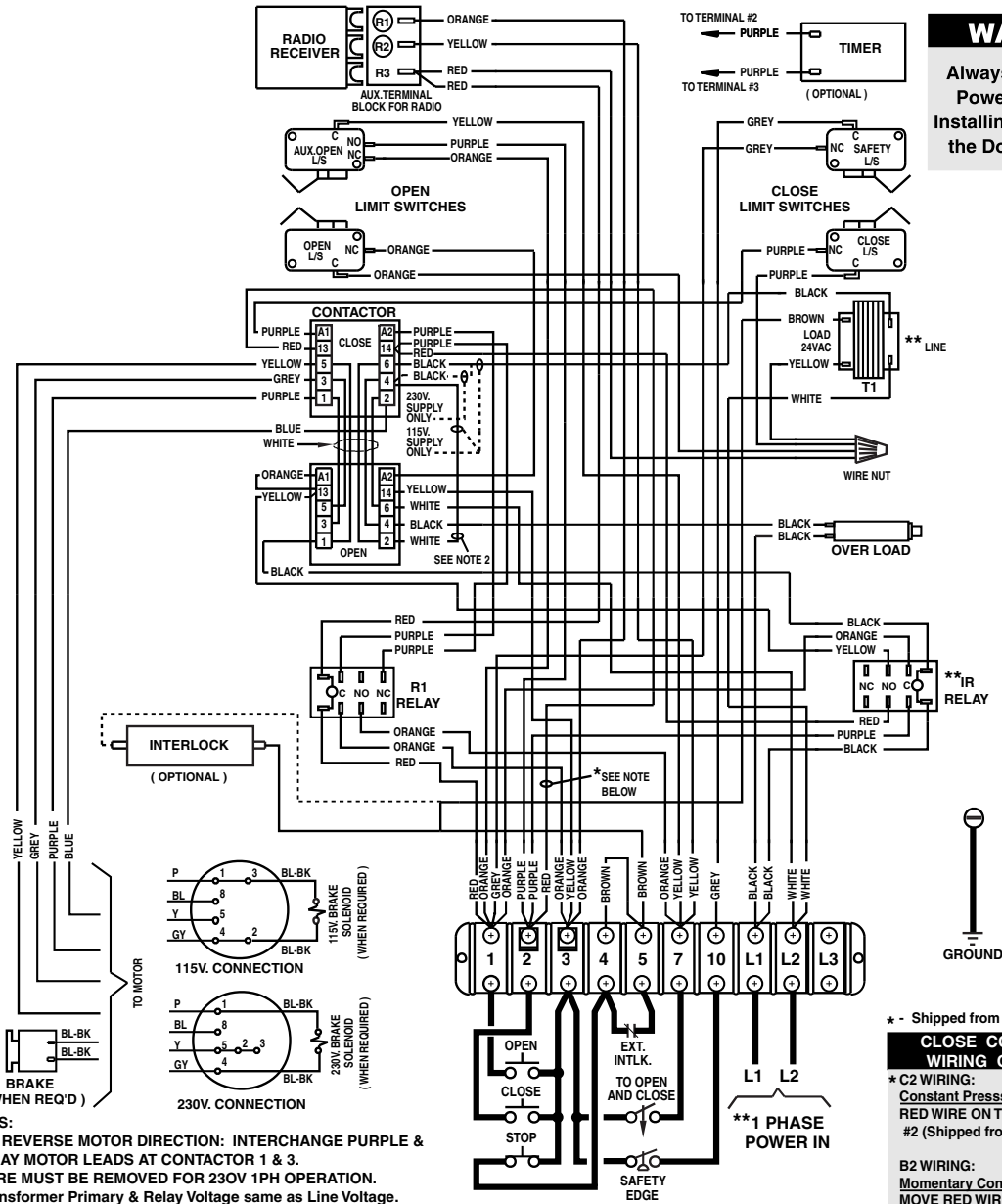

WARNING
Always Disconnect Power Whenever Installing or Servicing the Door Operator.

- NOTES:
 1) TO REVERSE MOTOR DIRECTION: INTERCHANGE PURPLE & GRAY MOTOR LEADS AT CONTACTOR 1 & 3.
 2) WIRE MUST BE REMOVED FOR 230V 1PH OPERATION.
 ** - Transformer Primary & Relay Voltage same as Line Voltage.

- * - Shipped from Factory
CLOSE CONTROL WIRING OPTIONS
 * C2 WIRING:
 Constant Pressure to Close
 RED WIRE ON TERMINAL #2 (Shipped from Factory)
 B2 WIRING:
 Momentary Contact to Close
 MOVE RED WIRE FROM TERMINAL #2 TO TERMINAL #3

THREE PHASE SCHEMATIC DIAGRAM

1742-3

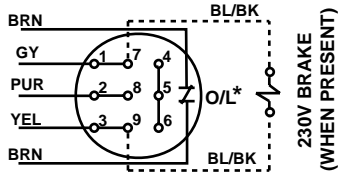

230 VOLT - 3 PHASE MOTOR CONNECTION

* - SEE NOTE #2

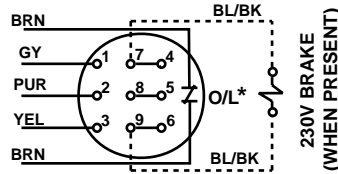

460 VOLT - 3 PHASE MOTOR CONNECTION

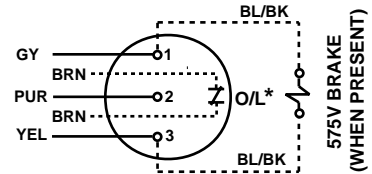

575 VOLT - 3 PHASE MOTOR CONNECTION

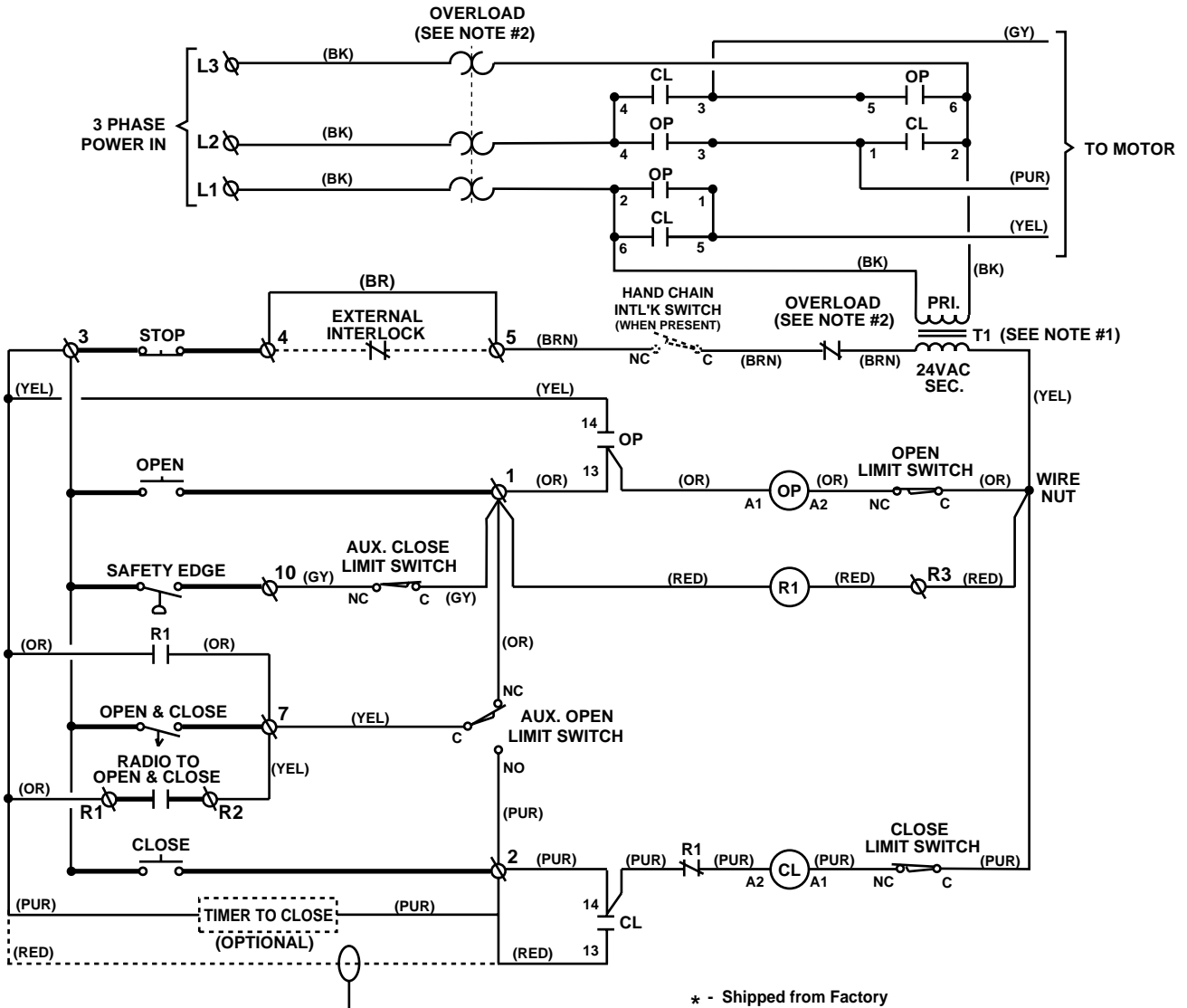

* - Shipped from Factory

CLOSE CONTROL WIRING OPTIONS

* C2 WIRING - Constant Pressure to Close
 RED WIRE ON TERMINAL #2 (Shipped from Factory)

B2 WIRING - Momentary Contact to Close
 MOVE RED WIRE FROM TERMINAL #2 TO TERMINAL #3

NOTE:

1. Voltage same as line voltage
2. Overload in motor for models up to 3/4 Hp, located in limit box for 1 Hp and above.

THREE PHASE WIRING DIAGRAM

1742-3

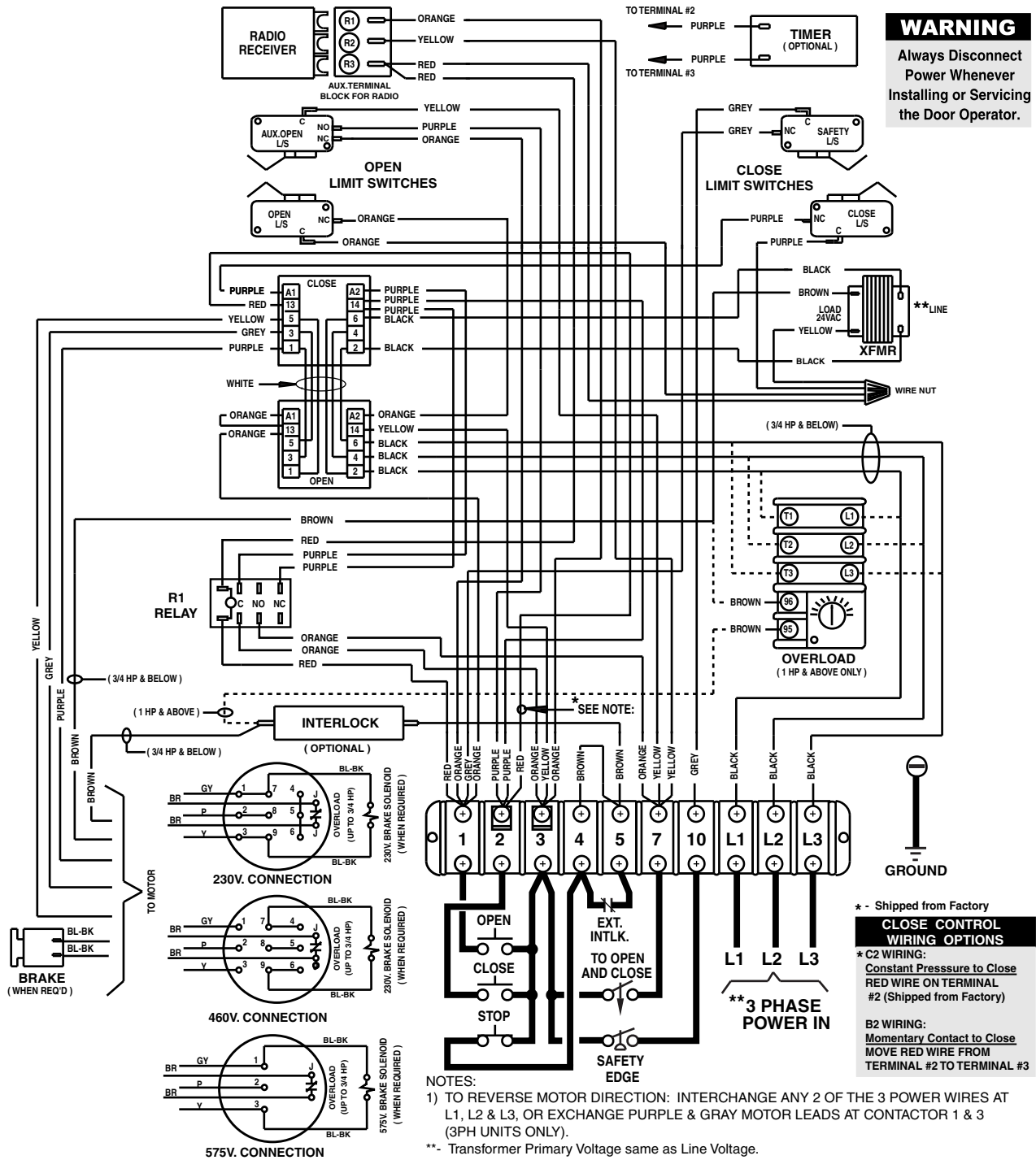

REPAIR PARTS KITS – ELECTRICAL BOX

Below are replacement kits available for your operator. For replacement of electrical box, motor or brake components be sure to match model number of your unit to kit number below to ensure proper voltage requirements. Optional modifications and/or accessories included with your operator may add or remove certain components from these lists. Please consult a parts and service representative regarding availability of individual components of kits specified below. Refer to page 11 for all repair part ordering information.

Complete Electrical Box Replacement Kits

To order a complete electrical box replacement kit, add a K- prefix to the model number of your operator. For example:

GH5011M (Operator) = K-GH5011M (Elec. Box Kit)

Electrical Box Sub-Assembly Kits

K72-12510 Limit Shaft Assembly
K75-12511 Limit Switch Assembly

Complete Gear Reducer Housing Kits

See Page 18 for more information

Shaft Assembly Kits

K72-12789 Hand Chain Shaft Assembly
K72-13379 Hand Chain Shaft Assembly
K75-12783 Disconnect Assembly

Complete Brake Assembly Kits

K75-12584 115V Models
K75-12585 230-460V Models
K75-12586 575V Models

Brake Solenoid Plate Assembly Kits

K75-11034 115V Models
K75-11035 230-460V Models
K75-11036 575V Models

Motor Kits

K20-1050C2 Models GH5011M, GH5021M
K20-3050C4 Models GH5023M, GH5043M, GH5038M
K20-3050M5 Model GH5053M
K20-5150C6 Models GH5025M
K20-1075C2 Models GH7511M, GH7521M
K20-3075C4 Models GH7523M, GH7543M, GH7538M
K20-3075C5 Model GH7553M
K20-5175C6 Model GH7525M
K20-1100C2 Models GH1011M, GH1021M
K20-3100C4 Models GH1023M, GH1043M, GH1038M
K20-3100C5T Model GH1053M
K20-5110C6 Model GH1025M
K20-1150C2 Models GH1511M, GH1521M
K20-3150C4 Models GH1523M, GH1543M, GH1538M
K20-3150C5T Model GH1553M
K20-5115C6 Model GH1525M
K20-3200C4 Models GH2023M, GH2043M, GH2038M
K20-3200C5 Model GH2053M
K20-3300C4 Models GH3023M, GH3043M, GH3038M

Individual Components

21-5115 Transformer, 115V Operators
21-5230 Transformer, 230V Operators
21-5460 Transformer, 380-460V Operators
21-5575 Transformer, 575V Operators

24-115-1 Relay, 115V 1Ph Operators
24-230-5 Relay, 230V 1Ph Operators

* COMPLETE ELECTRICAL BOX KITS			
Item	P/N	Description	Qty
1	03-8024-K	Contactors	1
2	10-13900	Electrical Box (No Tabs)	1
3	10-10115	Electrical Box Cover	1
4	21-5xxx	(See Individual Components)	1
5	23-10916	SPDT Interlock Switch	1
6	24-xxx-x	(See Individual Components)	1
7	24-24-1	24VAC DPDT Relay	1
8	25-2xxx	(See Overloads)	1
9	25-4xxx	(See Overloads)	1
10	42-10040	Terminal Block, Radio	1
11	42-110	Terminal Block, 10 Position	1

* Electrical Box Kits include parts from K72-12510 and K75-12511

K72-12510 LIMIT SHAFT ASSEMBLY KIT			
Item	P/N	Description	Qty
L1	11-10021	Limit Shaft, Standard T	1
L2	12-10028	Flange Bearing, 3/8" I.D.	2
L3	13-10024	Limit Nut	2
L4	15-48B9AXX	Sprocket 48B9 x 3/8" Bore	1
L5	80-10025	Washer, Shim 3/8" I.D. x .050 THK.	1
L6	80-10026	Washer, Shim 3/8" I.D. x .010 THK.	4
L7	86-RP04-100	Roll Pin, 1/8 DIA. x 1" Long	1
L8	87-E-038	E Ring, 3/8"	1

K75-12511 LIMIT SWITCH ASSEMBLY KIT			
Item	P/N	Description	Qty
S1	10-10013	Depress Plate	1
S2	10-12553	Nut Plate, Switch	4
S3	10-12806	Backup Plate	2
S4	18-10036	Spring, Depress Plate	2
S5	23-10041	Limit Switch	4
S6	31-12542	Standoff, Limit Switch	4
S7	82-PX04-20	Screw, #4-40 Pan Head Phillips	8
S8	82-PX06-16	Screw, #6-32 x 1" Pan Hd Phillips	2
S9	84-LH-06	Locknut, #6-32 Nylon Hex	2

OPERATOR	OVERLOADS									
	ITEM 8					ITEM 9				
	25-2006 6 Amp	25-2008 8 Amp	25-2010 10 Amp	25-2015 15 Amp	25-2025 25 Amp	25-4002-5K 1.6-2.5 Amp	25-4003-K 2.6-3.7 Amp	25-4004-K 2.5-4.0 Amp	25-4008-K 5.5-8.0 Amp	25-4011-5K 8.0-11.5 Amp
GH5011M			●							
GH5021M	●									
GH5025M	●									
GH7511M				●						
GH7521M		●								
GH7525M		●								
GH1011M				●						
GH1021M		●								
GH1023M								●		
GH1043M						●				
GH1053M						●				
GH1025M		●								
GH1038M						●				
GH1511M					●					
GH1521M			●							
GH1523M									●	
GH1543M							●			
GH1553M						●				
GH1525M			●							
GH1538M							●			
GH2023M									●	
GH2043M							●			
GH2053M							●			
GH2038M							●			
GH3023M										●
GH3043M									●	
GH3038M									●	

ILLUSTRATED PARTS – ELECTRICAL BOX

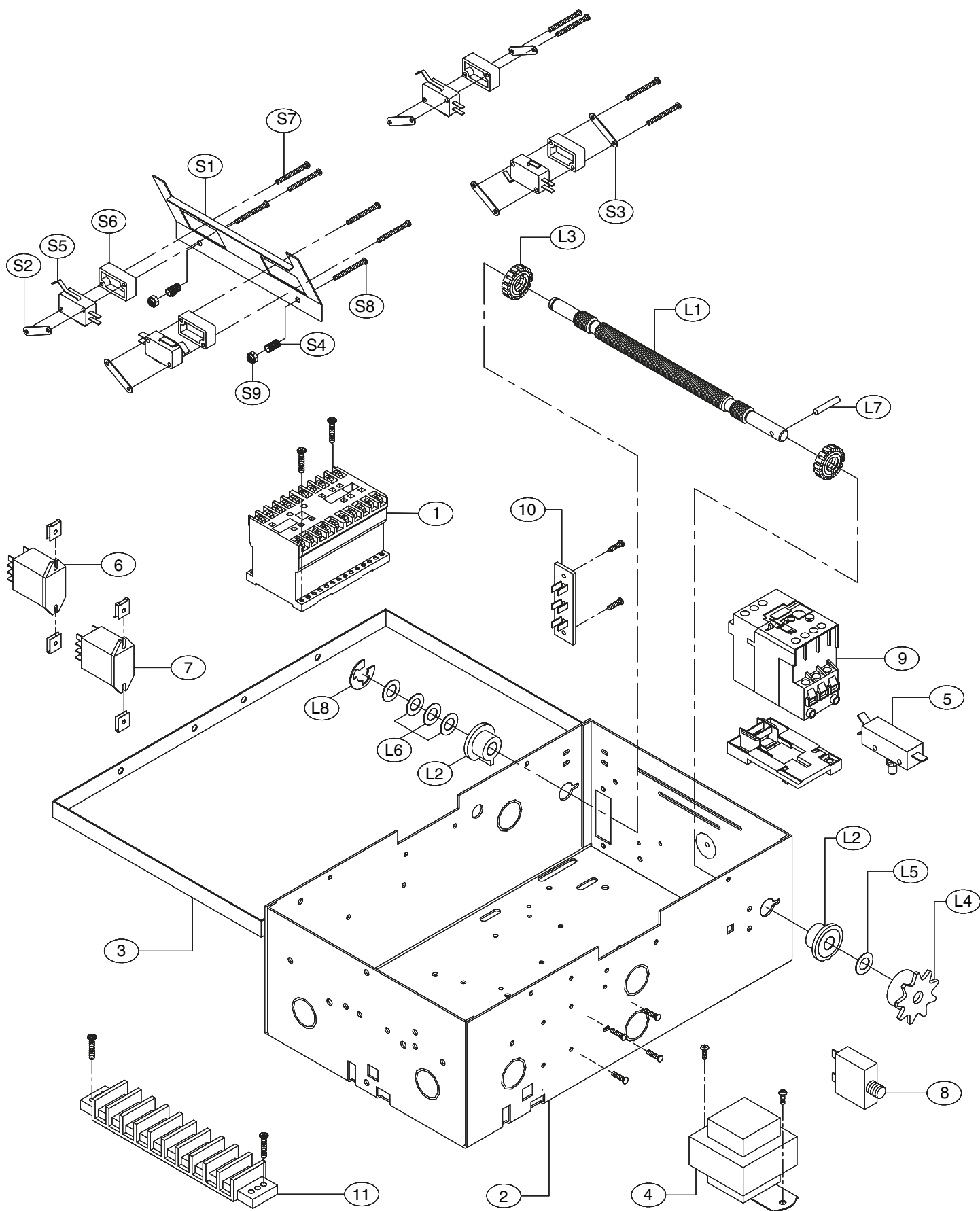

REPAIR PARTS KITS – MODEL GH

Refer to the parts lists below for replacement kits available for your operator. If optional modifications and/or accessories are included with your operator, certain components may be added or removed from these lists. Individual components of each kit may not be available. Please consult a parts and service representative regarding availability of individual components. Refer to page 11 for all repair part ordering information.

INDIVIDUAL PARTS			
ITEM	PART #	DESCRIPTION	QTY
1	10-11045	Elec. Box Mounting Bracket	1
2	15-48B18LGE	Sprocket, 48B18 LGE	1
	15-48B18QGH	Sprocket, 48B18 QGH (3HP Models)	1
3	15-50B12LGH	Sprocket, 50B12 LGH	1
	15-80B9QGH	Sprocket, 80B9 QGH (3HP Models)	1
4	See Page 16	Electrical Box	1
5	See Page 16	Motor	1
6	See Var. Comp.	Gear Reducer	1

K75-12783 DISCONNECT ASSEMBLY KIT			
ITEM	PART #	DESCRIPTION	QTY
D1	10-11021	GH Disconnect Lever	1
D2	10-11023	Bevel Gear Yoke	1
D3	10-11024	Brake Release	1
D4	10-11029	Actuator Bracket	1
D5	10-11030	Switch Actuator	1
D6	11-11106	Disconnect Shaft	1
D7	18-11007	GH Tension Spring	1
D8	19-8A-12	12ft. Of Sash Chain	1
D9	82-PX08-04T	Screw, #8-32 x 1/4" Self Tap	1
D10	82-SH10-14	Screw, #10-32 x 7/8" Long	2
D11	82-WX10-08T	Screw, #10-32 x 1/2" Serrated Fl.	2
D12	84-FN-10	Nut, #10-32 Serrated Flange	2
D13	85-FW-50	USS Flatwasher, 3/4"	3
D14	85-LS-10	#10 Lockwasher ZP	2
D15	86-CP04-112	Cotter Pin, 1/8" x 1-3/4" Long	3
D16	86-RP06-300	Roll Pin, 3/16" x 3" Black Oxide	1

COMPLETE GEAR REDUCER HOUSING KITS			
KIT REQUIRED	FOR	OPERATOR(S)	
K75-12829		Up to 1HP, 115 Volts	
K75-12830		Up to 1HP, 230-460 Volts	
K75-12831		Up to 1HP, 575 Volts	
K75-12832		1.5 to 2HP, 230-460 Volts	
K75-12833		1.5 to 2HP, 575 Volts	
K75-12834		3HP, 230-460 Volts	
ITEM	PART #	DESCRIPTION	QTY
G1	10-11006	Housing Support Bracket	2
G2	10-11026M1	Gear Brake Housing	1
	10-12453M1	Gear Brake Housing (3HP Models)	1
G3	10-11046M1	Housing Cover	1

* Gear Housing Kits also include:

K75-12788	Disconnect Assembly Kit
K72-12789	Hand Chain Shaft Kit
K72-13379	Hand Chain Shaft Kit (3HP Models)
K75-12584	Brake Assembly Kit (115V Models)
K75-12585	Brake Assembly Kit (230-460V Models)
K75-12586	Brake Assembly Kit (575V Models)

* Brake Kit Voltage same as Operator Voltage.

K72-12789 OR K72-13379 HAND CHAIN SHAFT KIT			
ITEM	PART #	DESCRIPTION	QTY
H1	08-11012	Bevel Gear, 5/8" ID	1
	75-13334	Bevel Gear Assy, 3/4" ID (3HP)	1
H2	08-11013	Bevel Gear, 3/4" ID	1
	08-13333	Bevel Gear, 3/4" ID 24 Tooth (3HP)	1
H3	10-10882	Hand Chain Guide	1
H4	11-11105	Hand Chain Shaft, GH	1
H5	12-10029	Bearing, 3/4" I.D.	2
H6	12-10883	Nyliner Bearing	1
H7	18-11008	Compression Spring, GH	1
H8	75-10884	Chain Wheel Assembly	1
H9	80-10022	Shim Washer, Thick	4
H10	80-11014	Washer, .656 I.D. x 1.25 O.D.	1
H11	86-RP08-108	Roll Pin, 1/4" x 1-1/2" Long	1
H12	86-RP10-110	Roll Pin, 5/16" x 1-5/8" Long	1
H13	86-RP10-208	Roll Pin, 5/16" x 2-1/2" Long	1
H14	87-E-062	E Ring, 5/8"	1
H15	87-E-075	E Ring, 3/4"	4

BRAKE ASSEMBLY KITS			
KIT REQUIRED	FOR	OPERATOR(S)	
K75-12584		115 Volt Models	
K75-12585		230-460 Volt Models	
K75-12586		575 Volt Models	
ITEM	PART #	DESCRIPTION	QTY
B1	07-10179	Brake Hub	1
B2	10-10190	Brake Release Lever	1
B3	10-10191	Brake Disk	1
B4	11-10192	Spring Cup for Brake Assembly	4
B5	11-10193	Brake Stud	4
B6	18-10194	Spring, Compression x .87"	4
B7	31-10186	Spacer, .20" x .31" Long	2
B8	75-10184	Brake Pressure Plate Assembly	1
B9	75-11034	Brake Solenoid Assembly (115V)	1
	75-11035	Brake Solenoid Assembly (230V)	1
	75-11036	Brake Solenoid Assembly (575V)	1
B10	80-9001	Feather Key	1
B11	87-P-062	Push on Fastener, 5/8" Int. Star	1

VARIABLE COMPONENTS			
ITEM	PART #	DESCRIPTION	QTY
	75-11034	Brake Solenoid Assy (115V Opers)	1
B9	75-11035	Brake Solenoid Assy (230-460V Opers)	1
	75-11036	Brake Solenoid Assy (575V Opers)	1
	32-11009	Gear Reducer (1 HP Opers, 45:1)	1
6	32-11010	Gear Reducer (1.5-2 HP Opers, 45:1)	1
	32-11011	Gear Reducer (3 HP Opers, 45:1)	1

ILLUSTRATED PARTS – MODEL GH

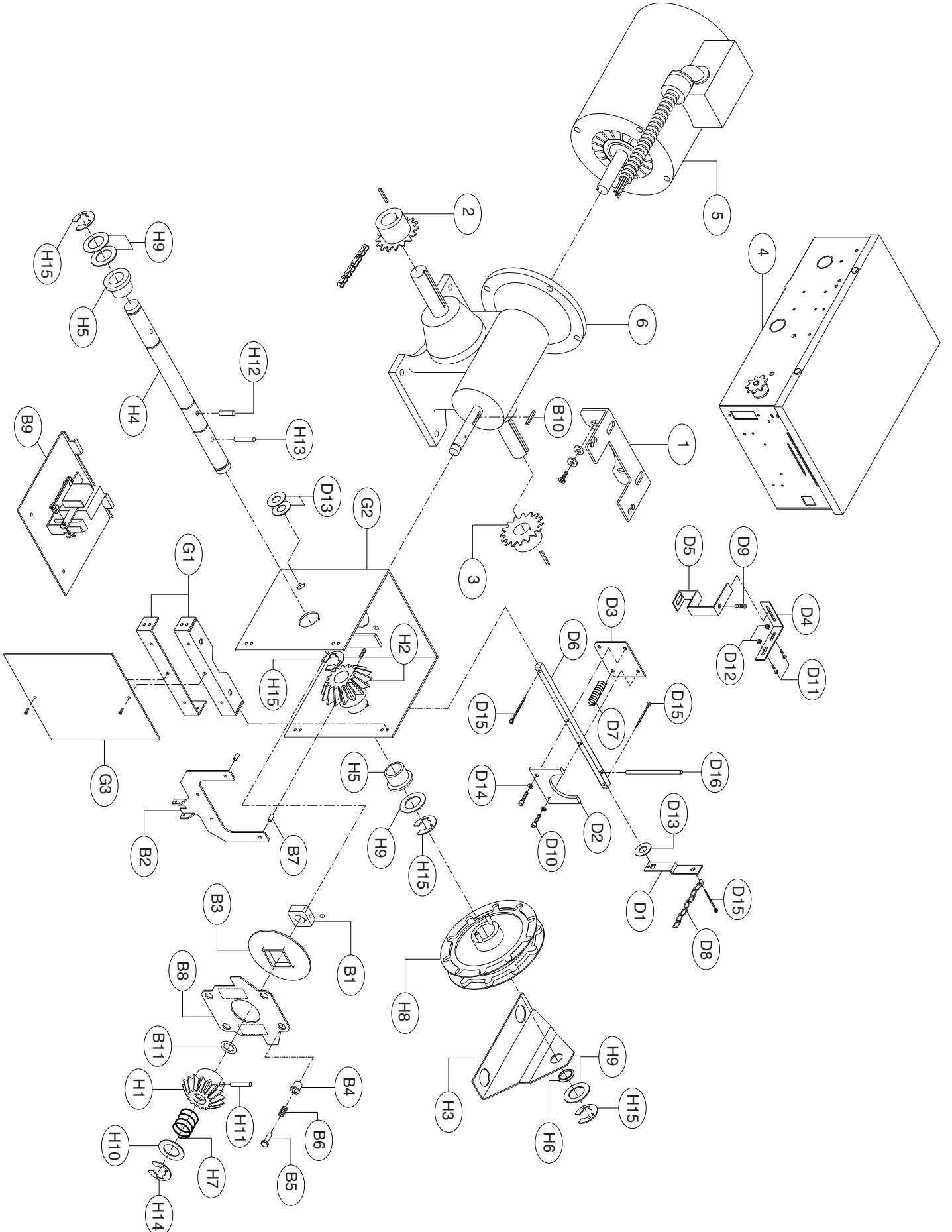

CONTROL CONNECTION DIAGRAM

IMPORTANT NOTES:

- 1) The 3-Button Control Station provided must be connected for operation.
- 2) If a STOP button is not used, a jumper must be placed between terminals 3 and 4.
- 3) Auxiliary control equipment may be any normally open two wire device such as pullswitch, single button, loop detector, card key or such device.

ATTENTION ELECTRICIAN:
USE 16 GAUGE OR HEAVIER WIRE
FOR ALL CONTROL CIRCUIT WIRING.

3 BUTTON STATION or 3 POSITION KEYSWITCH w/ SPRING RETURN TO CENTER AND STOP BUTTON		
<p>STANDARD</p> <p style="text-align: center;">ALL CONTROL WIRING TYPES</p>	<p>2 OR MORE</p> <p style="text-align: center;">ALL CONTROL WIRING TYPES</p>	<p>KEY LOCKOUT</p> <p style="text-align: center;">ALL CONTROL WIRING TYPES</p>
2 BUTTON STATION or 3 POSITION KEYSWITCH w/ SPRING RETURN TO CENTER		1 BUTTON STATION or ANY AUXILIARY DEVICE
<p>STANDARD</p> <p style="text-align: center;">ALL CONTROL WIRING TYPES</p>	<p>2 OR MORE</p> <p style="text-align: center;">ALL CONTROL WIRING TYPES</p>	<p style="text-align: center;">B2 or T1 WIRING TYPES ONLY</p>
SENSING DEVICE TO REVERSE OR STOP		RESIDENTIAL RADIO CONTROLS
<p style="text-align: center;">ALL CONTROL WIRING TYPES</p>		<p>*OPEN TIMER TO CLOSE</p> <p style="text-align: center;">ALL CONTROL WIRING TYPES *T1 WIRING - RADIO TO OPEN ONLY</p>
TIMER TO CLOSE w/ WARNING LIGHT		EXTERNAL INTERLOCK
<p>Warning Light will activate 15 sec. before door closes.</p> <p style="text-align: center;">T1 CONTROL WIRING ONLY</p>		<p style="text-align: center;">Remove Jumper When Interlock is Used</p> <p style="text-align: center;">ALL CONTROL WIRING TYPES</p>