

LM550EVGBSA

# WEATHER RESISTANT ROLLING GARAGE DOOR OPENER



## KEY FEATURES

### WEATHER RESISTANT

Market Leading IP34 Rating

### LIFTING POWER

Powers 120kg Doors

## POWERFUL AND RELIABLE

**WEATHER RESISTANT** MARKET LEADING IP34 RATED HOUSING TO HELP PROTECT FROM THE ELEMENTS

**SLIMLINE DESIGN** DESIGNED FOR TIGHT SPACES. THE OPENER ONLY REQUIRES MINIMUM SIDE ROOM OF 40MM

**LED LIGHTING** 9 ULTRABRIGHT LED'S BUILT INTO THE OPENER

**DUAL SPEED** TWO TRAVEL SPEEDS PROVIDES GREATER CONTROL AND PERFORMANCE

**QUIET AND POWERFUL MOTOR** THE POWERFUL AND FAST DC MOTOR IS QUIET AND BUILT TO LAST WITH THE STRENGTH TO OPEN ANY GARAGE DOOR OR SHED

**IMPROVED TRANSMITTER RANGE** TESTED AGAINST OTHER PRODUCTS, THESE TRANSMITTERS HAVE UP TO 18% BETTER RANGE WHICH MEANS YOU CAN START OPENING YOUR GARAGE DOOR SOONER

**2 YEAR WARRANTY** FULL 2 YEAR PRODUCT WARRANTY FOR PEACE OF MIND

## SECURE

**TIMER-TO-CLOSE** AUTOMATICALLY CLOSES THE DOOR AFTER A PRESET AMOUNT OF TIME

**SECURITY+ 2.0®** TRANSMITTERS COMMUNICATE ON MULTIPLE FREQUENCIES WITH ENCRYPTED ROLLING CODE. THIS ENSURES THE STRONGEST FREQUENCY IS SELECTED EVERY TIME, VIRTUALLY ELIMINATING INTERFERENCE WHILE PROVIDING THE HIGHEST LEVEL OF SECURITY

**E-LOCK** CONTROL PANEL BUTTONS CAN BE LOCKED, PROVIDING BETTER SECURITY

## INCLUDED ACCESSORIES

### PREMIUM+ REMOTE CONTROL

Each button is independently programmable and backed by Security+2.0 and Security+



ME960-LM

### WIRED PUSH BUTTON

Illuminated push button that allows you to open 1 garage door



75EV

## POWERFUL ADD-ONS

### PHOTOCELLS

(Safety IR Beams) auto-reverses the door if there's an obstruction



771ESA

## LM550EVGBSA

WEATHER RESISTANT ROLLING  
GARAGE DOOR OPENER

# MASTERFUL ENGINEERING.

## MOTOR



- Heavy-Duty 24V DC
- Automatic Thermal Protection
- Permanent Lubrication

## POWER



- 220-240V AC
- 50-60 Hz
- 2.7A Current Rating
- UL® Listed
- 6' Power Cord (3-Prong)

## MECHANICS



- Steel Chassis and Plastic Cover
- Auto-Force Adjustment for Changing Weather and Environmental Conditions
- Electronic Limits for Easy Setup

## DIMENSIONS



- Max. Door Size: 3m high by 5m wide. Max 15m2.
- Max spring balanced load 15kg

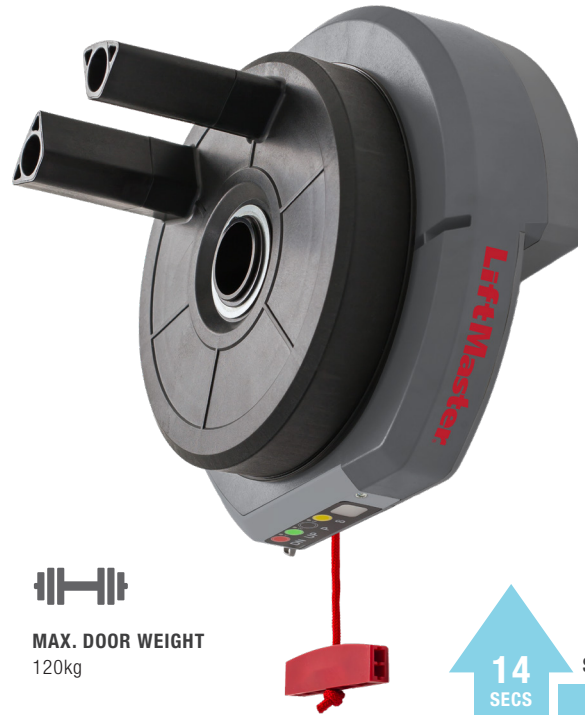

**MAX. DOOR WEIGHT**  
120kg

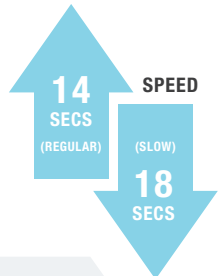

# SAFETY AND SECURITY.

## SAFETY

- Alert-2-Close/Unattended Close Operation<sup>††</sup>
- Emergency/Quick Release
- Ventilation/Pet Opening
- Down Safety Reverse
- Up Safety Stop
- Maintenance Alert System

<sup>††</sup> Note: to reduce the risk of injury to persons, only use Alert-2-Close/Unattended Close Operation features when installed with a sectional door.

## SECURITY

### SECURITY+ 2.0®

#### RADIO CONTROLS

Premium+ Remote (ME960-LM)

- Remote Control: 433 MHz Tri-Band\*
- Tri-band on Security+ 2.0 coding only.

# SHIPPING.

## SHIPPING WEIGHT

6.35kg

## CARTONS (1)

CARTON 1: L 33cm x W 32cm x H 19cm

- Garage Door Opener (LM550EVGBSA)
- ME960-LM Security+2.0 Premium+ Remote Control
- 75EV Wired Push Button

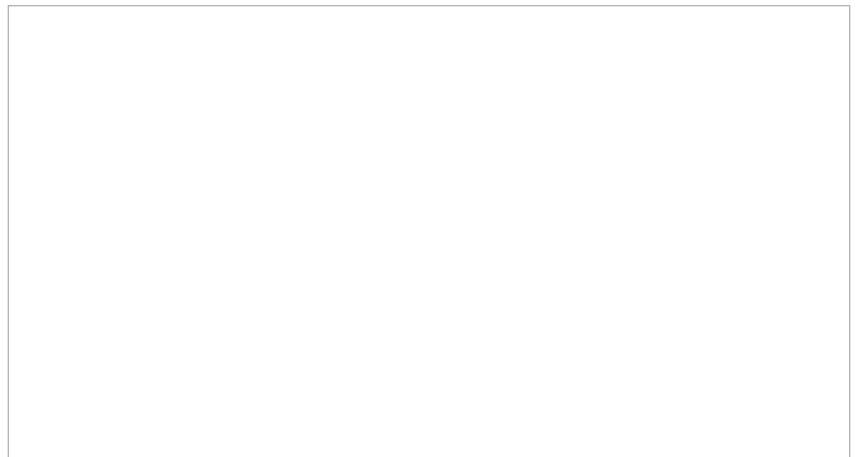

## LM550EVGBSA

WEATHER RESISTANT ROLLING  
GARAGE DOOR OPENER